

Long skirt made of lightweight fabric

1. If there are no instructions to use a specific stitch, use the straight stitch.
2. Presser foot "J" (straight stitch) and overcasting foot "G" will be used.



Let's sew a three-tiered long skirt made of lightweight fabric. If you have plenty of fabric, you can sew straight lines to connect square pieces to make fashionable clothes to wear to a party.

Materials

- Cotton voile (120 cm wide × 175 cm)
 - Elastic tape (2 cm wide × 65 cm)
- Prepare a length of the waist size + 2 cm.

Cutting diagram

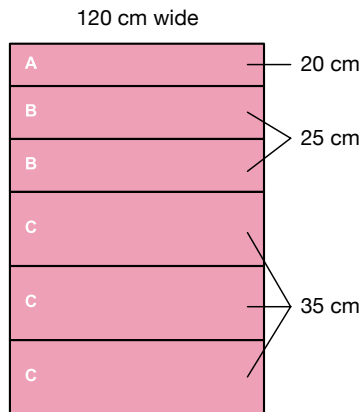

- 1 Cut out each piece. Use the selvage on both ends.

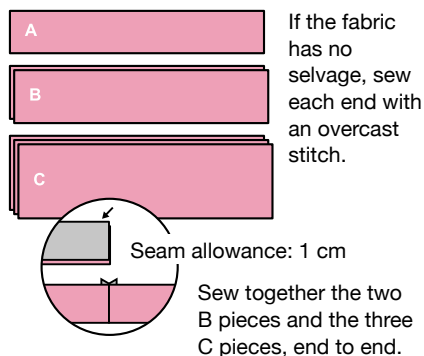

- 2 Sew overcast stitching along the edges of the pieces that were sewn together.

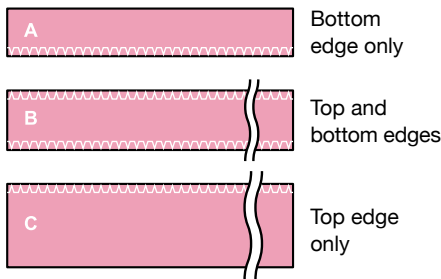

- 3 In order to create gathers, machine-baste (straight stitching with a long stitch length) along the top edges of B and C.

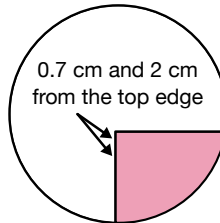

Pull both ends of the thread to create gathers.

- 4 Sew together the pieces.

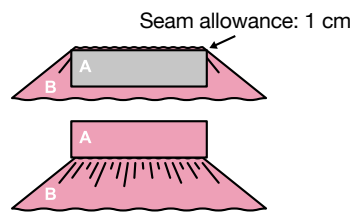

Adjust the length of the gathered top edge of B to the length of the bottom edge of A, pin them together, and then stitch together.

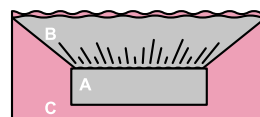

Adjust the length of the gathered top edge of C to the length of the bottom edge of B, pin them together, and then stitch together.

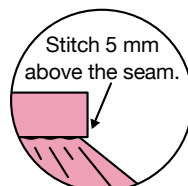

Fold up the seam allowances, iron them, and then sew them in place by stitching from the right side.

- 5 Sew the ends together to form a tube.

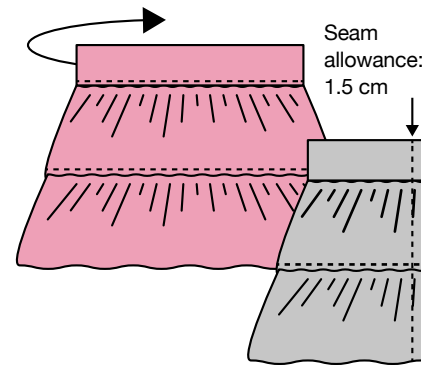

- 6 Fold back twice and stitch at the waist and hem. In order to pass the elastic tape through, leave a 5 cm opening on the side of the waist.

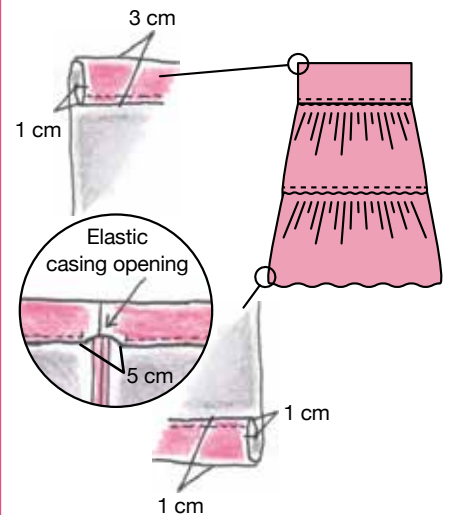

- 7 Pass the elastic tape through to complete the project. Overlap 5 cm of the elastic tape, and then sew together with a stretch stitch.

