



# User's Guide

**PT-N10**

**PT-N20**

**PT-N25BT**

## Table of Contents

<b>Before You Use Your Label Maker .....</b>	<b>1</b>
Definitions of Notes .....	2
General Precautions .....	3
Trademarks and Licenses .....	4
Important Note .....	5
<b>Set Up Your Label Maker .....</b>	<b>6</b>
Parts Description .....	7
LCD Overview .....	9
Keyboard Overview .....	11
Insert Tape Cassette .....	14
Install Batteries .....	18
Connect the AC Adapter .....	21
Turn the Label Maker On/Off .....	22
Set Language .....	23
Set Measurement Units .....	24
Enable or Disable Bluetooth .....	25
LED Patterns and Indications .....	26
Feed Tape .....	27
Adjust LCD Contrast .....	28
<b>Edit a Label .....</b>	<b>29</b>
Add Text to Your Label .....	30
Make a Two-Line Label .....	31
Delete Text .....	33
Enter Symbols .....	34
Enter Symbols Using the Symbol Function .....	35
Print the Pictograph List .....	36
Symbol Options .....	37
Enter Accented Characters .....	41
Accented Character Options .....	42
Set Character Attributes .....	44
Attribute Setting Options .....	45
Set Label Length .....	46
Set Underline or Frame .....	47
Underline and Frame Options .....	48
<b>Print Labels .....</b>	<b>51</b>
Preview Labels .....	52
Print Labels .....	53
Sequential Printing .....	55
Mirror Printing .....	56
Set Margins .....	57
Margin Options .....	58
Adjust the Label Length .....	60
Adjust the Print Density .....	61
<b>Use the File Memory .....</b>	<b>62</b>





Save Label Files.....	63
Print or Open a Saved Label.....	64
<b>Print Labels Using Mobile Devices.....</b>	<b>65</b>
Install Brother P-touch Design&Print 2 App .....	66
Connect the Printer to a Mobile Device Using Bluetooth .....	67
Create Labels and Print Them Using a Mobile Device .....	68
<b>Routine Maintenance .....</b>	<b>69</b>
Maintenance.....	70
<b>Troubleshooting .....</b>	<b>74</b>
If You Are Having Difficulty with Your Label Maker .....	75
Error and Maintenance Messages .....	78
Check the Version Information .....	80
Reset the Label Maker .....	81
Reset the Printer to the Factory Settings .....	82
<b>Appendix.....</b>	<b>83</b>
Specifications .....	84
Brother Help and Customer Support.....	85

## Before You Use Your Label Maker

- [Definitions of Notes](#)
- [General Precautions](#)
- [Trademarks and Licenses](#)
- [Important Note](#)

## Definitions of Notes

We use the following symbols and conventions throughout this User's Guide:

 <b>DANGER</b>	DANGER indicates an imminently hazardous situation which, if not avoided, will result in death or serious injuries.
 <b>WARNING</b>	WARNING indicates a potentially hazardous situation which, if not avoided, could result in death or serious injuries.
 <b>CAUTION</b>	CAUTION indicates a potentially hazardous situation which, if not avoided, may result in minor or moderate injuries.
<b>IMPORTANT</b>	IMPORTANT indicates a potentially hazardous situation which, if not avoided, may result in damage to property or loss of product functionality.
<b>NOTE</b>	NOTE specifies the operating environment, conditions for installation, or special conditions of use.
	The tips icon indicates helpful hints and supplementary information.
<b>Bold</b>	Bold style identifies buttons on the machine's control panel or computer screen.
<i>Italics</i>	Italicized style emphasizes an important point or refers you to a related topic.
Courier New	Courier New font identifies messages shown on the machine's LCD.



### Related Information

- [Before You Use Your Label Maker](#)

## General Precautions

- Depending on the area, material, and environmental conditions, the label may peel off or become permanently affixed, the color of the label may change or be transferred to other objects, or the printed characters may fade. Before affixing the label, check the environmental conditions and surface material. Test the label by affixing a small piece of it to an inconspicuous area of the intended surface.
- Labels may be difficult to attach to surfaces that are wet, dirty, or uneven.
- Depending on the color of the label and the color of the material to which the label is affixed, the color of the underlying material may be visible through the label, or the label color may appear different. If this is a problem, use two labels layered on top of each other or use a dark-colored label.
- We recommend using genuine Brother supplies to ensure stable print quality and performance.
- Be sure to read the instructions provided with the Tape Cassette and observe all precautions noted in the instructions.
- When printing multiple labels, make sure that the Tape Cassette contains enough tape. If the Label Maker runs out of tape, you must install a new Tape Cassette and print any unprinted labels.
- DO NOT use the Label Maker, components, or supplies in any way or for any purpose not described in this guide. Doing so may result in accidents or damage.
- Use a soft wipe to clean the Print Head; never touch the Print Head directly with your hands.
- DO NOT apply excessive pressure to the Tape Cutter Lever.
- DO NOT try to print if the cassette is empty; it will damage the Print Head.
- DO NOT pull the tape while printing or feeding; it will damage the tape and the Label Maker.
- DO NOT leave any rubber, vinyl, or products made of rubber or vinyl on the Label Maker for an extended period of time, otherwise they may leave marks or residue on the Label Maker.
- Any data stored in the printer's memory will be lost if there is a failure, repair, or if the batteries discharge completely.
- White, gold, and silver objects may not always print clearly.
- The displayed label length may slightly differ from the actual length of the printed label due to printing tolerance.
- When power is disconnected for more than two minutes, all text and format settings will be lost.
- A protective clear plastic film is placed on the LCD during manufacturing and shipping. Remove this film prior to use.
- PT-N20/PT-N25BT:  
DO NOT transport the Label Maker while the cable is connected, as the connector may get damaged.
- PT-N25BT:  
Printed characters may look different than previewed, as your device's screen may have a higher resolution than the Label Maker's screen.
- PT-N25BT:  
Small text may not be printed as clearly as it is displayed on your device's screen.



### Related Information

- [Before You Use Your Label Maker](#)

## Trademarks and Licenses

- Android is a trademark of Google LLC.
- Google Play and the Google Play logo are trademarks of Google LLC.
- The Bluetooth<sup>®/MD</sup> word mark and logos are registered trademarks owned by Bluetooth SIG, Inc. and any use of such marks by Brother Industries, Ltd. is under license. Other trademarks and trade names are those of their respective owners.
- iPad and iPhone are trademarks of Apple Inc.
- Portions of this software are copyright © 2014 The FreeType Project ([www.freetype.org](http://www.freetype.org)). All rights reserved.
- Adobe<sup>®</sup> and Reader<sup>®</sup> are either registered trademarks or trademarks of Adobe Systems Incorporated in the United States and/or other countries.

**Any trade names and product names of companies appearing on Brother products, related documents and any other materials are all trademarks or registered trademarks of those respective companies.**



### Related Information

- [Before You Use Your Label Maker](#)

## Important Note

- The contents of this document and the specifications of this Label Maker are subject to change without notice.
- Brother reserves the right to make changes without notice in the specifications and materials contained herein and shall not be responsible for any damages (including consequential) caused by the reliance on the materials presented, including, but not limited to, typographical and other errors relating to the publications.
- This Label Maker does not support Wi-Fi connection.
- Screen images in this document may differ depending on your product model.
- Before using the Label Maker, make sure you read all the documents included with it for information about safety and operation.
- The Label Maker shown in the illustrations may be different from your Label Maker.
- The available supplies may vary depending on your country or region.
- Before giving your Label Maker to anyone else, replacing it, or disposing of it, we strongly recommend resetting it to its factory settings to remove all personal information.



### Related Information

- [Before You Use Your Label Maker](#)
-



## Set Up Your Label Maker

- [Parts Description](#)
- [LCD Overview](#)
- [Keyboard Overview](#)
- [Insert Tape Cassette](#)
- [Install Batteries](#)
- [Connect the AC Adapter](#)
- [Turn the Label Maker On/Off](#)
- [Set Language](#)
- [Set Measurement Units](#)
- [Enable or Disable Bluetooth](#)
- [Feed Tape](#)
- [Adjust LCD Contrast](#)

## Parts Description

>> PT-N10

>> PT-N20/PT-N25BT

### PT-N10

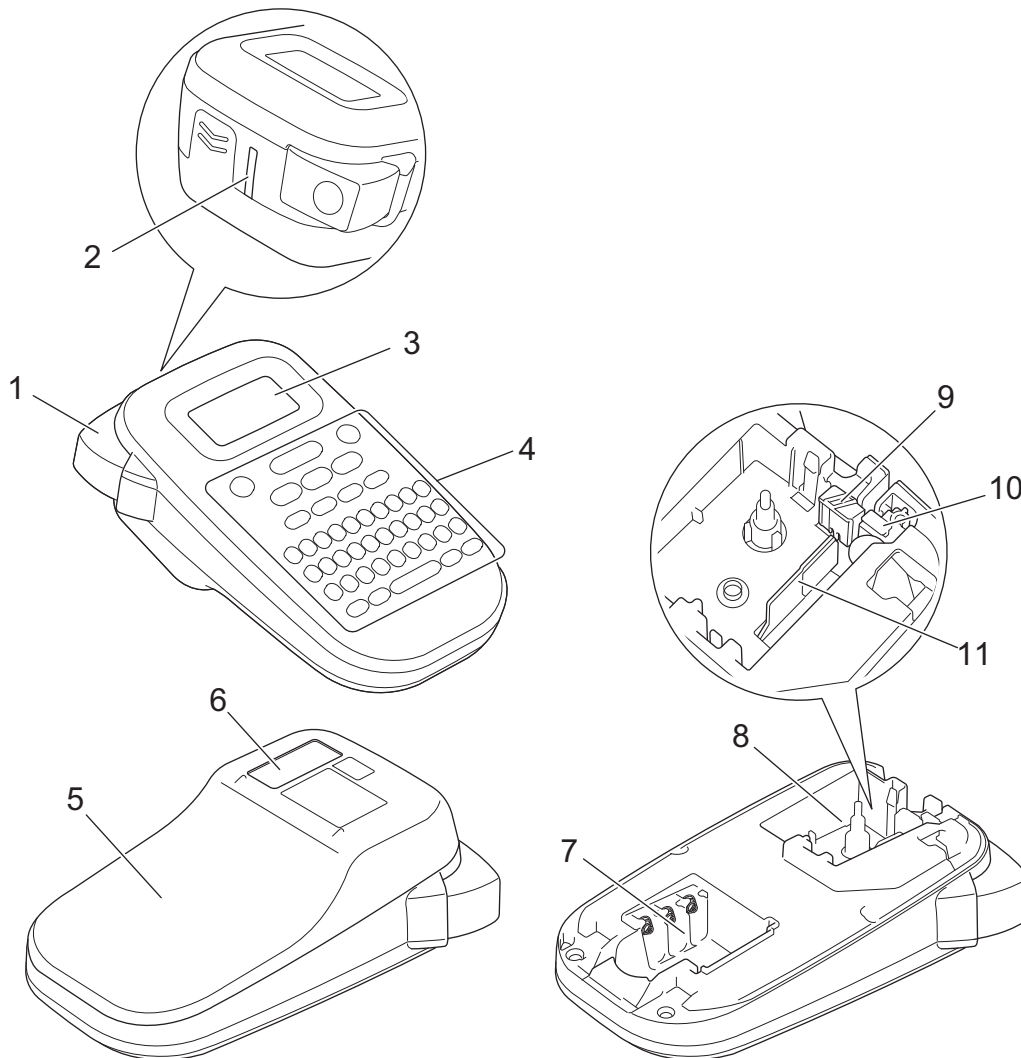

1. Tape Cutter Lever
2. Tape Exit Slot
3. Liquid Crystal Display (LCD)
4. Keyboard
5. Tape Cassette Compartment Cover
6. Tape Viewer
7. Battery Compartment
8. Tape Cassette Compartment
9. Cutter Board
10. Tape Cutter
11. Print Head

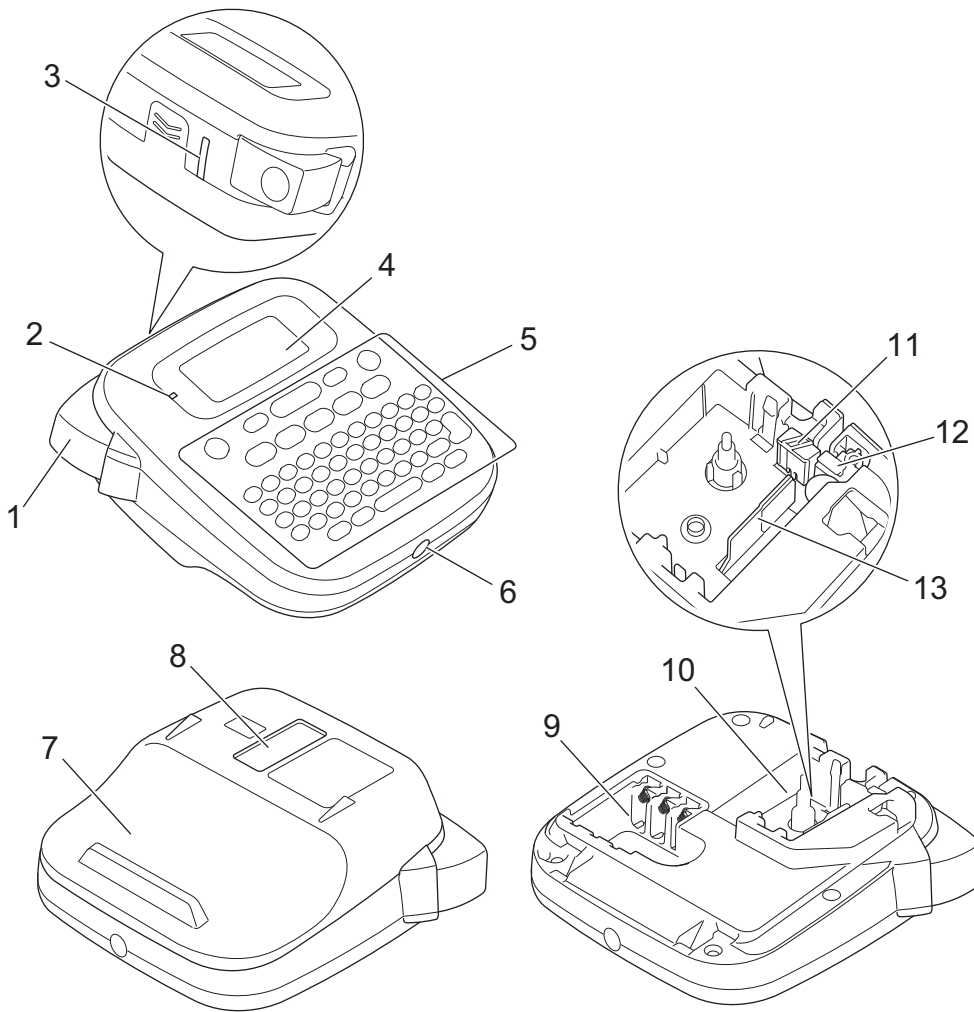

1. Tape Cutter Lever
2. Bluetooth LED (PT-N25BT)
3. Tape Exit Slot
4. Liquid Crystal Display (LCD)
5. Keyboard
6. AC Adapter Jack
7. Tape Cassette Compartment Cover
8. Tape Viewer
9. Battery Compartment
10. Tape Cassette Compartment
11. Cutter Board
12. Tape Cutter
13. Print Head

 **Related Information**

- [Set Up Your Label Maker](#)

## LCD Overview

>> PT-N10

>> PT-N20/PT-N25BT

### PT-N10

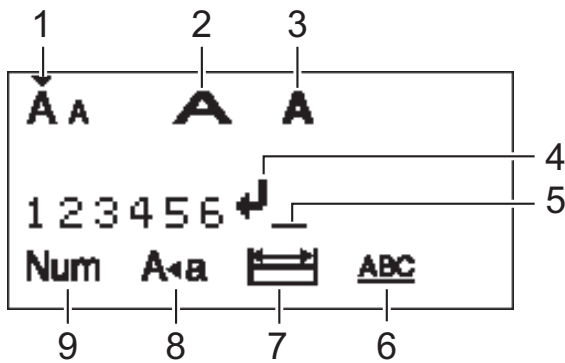

- 1. Character size**  
Indicates the current character size.
- 2. Character width**  
Indicates the current character width.
- 3. Character style**  
Indicates the current character style.
- 4. Return mark**  
Indicates the end of a line of text.
- 5. Cursor**  
Indicates the current data entry position.  
New characters appear to the left of the cursor.
- 6. Underline/Frame**  
Indicates if an underline or a frame is set.
- 7. Label length**  
Indicates if the label length is set.
- 8. Caps mode**  
Indicates if the Caps lock is enabled.
- 9. Number Lock**  
Indicates if the Number lock is enabled.

### PT-N20/PT-N25BT

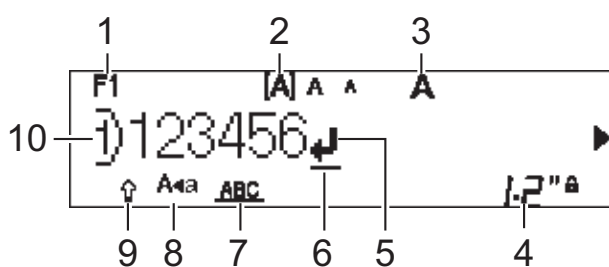

- 1. Current font**  
Indicates the current font.

---

**2. Character size**

Indicates the current character size.

**3. Character style**

Indicates the current character style.

**4. Label length**

Indicates if the label length is set.

**5. Return mark**

Indicates the end of a line of text.

**6. Cursor**

Indicates the current data entry position.

New characters appear to the left of the cursor.

**7. Underline/Frame**

Indicates if an underline or a frame is set.

**8. Caps mode**

Indicates if the Caps lock is enabled.

**9. Shift**

Indicates if the Shift lock is enabled.

**10. Line number**

Indicates line numbers within the label layout.

**Related Information**

- [Set Up Your Label Maker](#)
-

## Keyboard Overview

>> PT-N10

>> PT-N20/PT-N25BT

### PT-N10

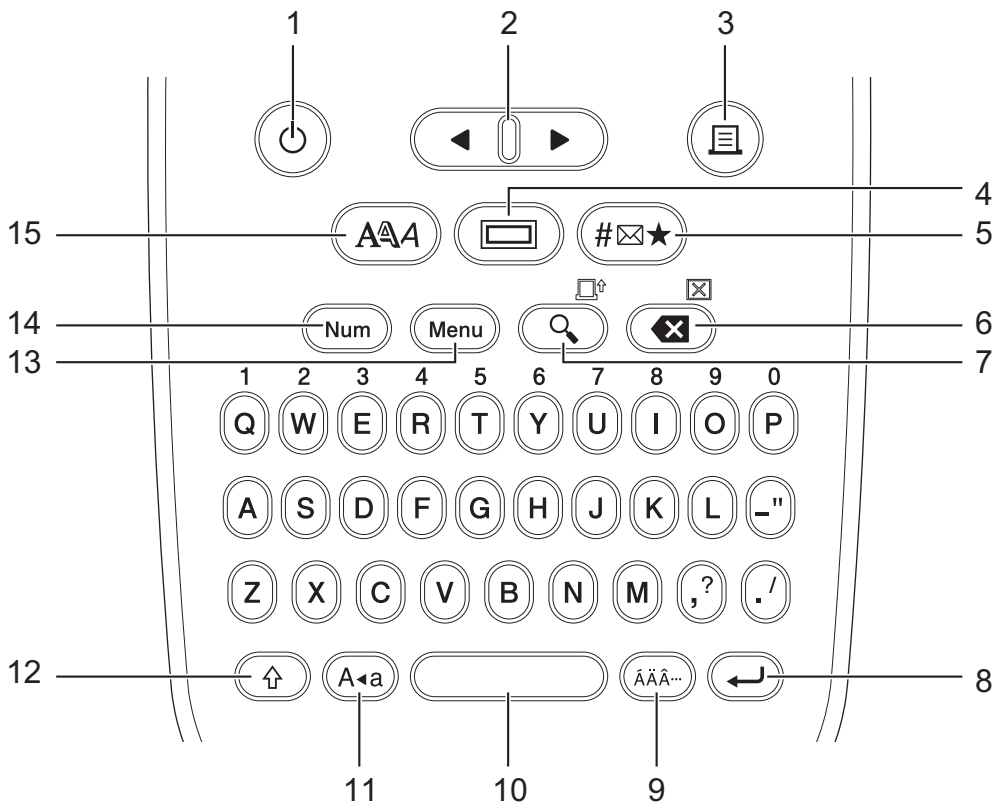

#### 1. Power

Press to turn on or off the Label Maker.

#### 2. Cursor

Press to move the cursor in the direction of the arrow.

#### 3. Print

Press to print.

#### 4. Underline/Frame

Press to select an underline or a frame.

#### 5. Symbol

Press to select and insert a symbol or to print the symbol list.

#### 6. Backspace/Clear

Press to delete any character to the left of the cursor.

To clear all text and format settings, press **Backspace/Clear** and the **Shift** key simultaneously.

#### 7. Preview/Feed

Press to view an image of the label before printing.

To feed the tape, press **Preview/Feed** and the **Shift** key simultaneously.

#### 8. Enter

Press to confirm your selection.

## 9. Accent

Press to select an accented character.

## 10. Space

Press to insert a blank space.

Press to return to the default value.

## 11. Caps

Press to use only uppercase letters (ALL CAPS mode).

## 12. Shift

Press and hold this key before pressing a letter key to type an uppercase letter.

To move the cursor to the beginning of your text, press **Shift** and the ◀ key simultaneously.

To move the cursor to the end of your text, press **Shift** and the ▶ key simultaneously.

## 13. Menu

Press to access the main menu.

## 14. Number Lock

Press to enter numbers. Press again to release the Number lock.

## 15. Character Style

Press to set the character font, size, width, and style.

## PT-N20/PT-N25BT

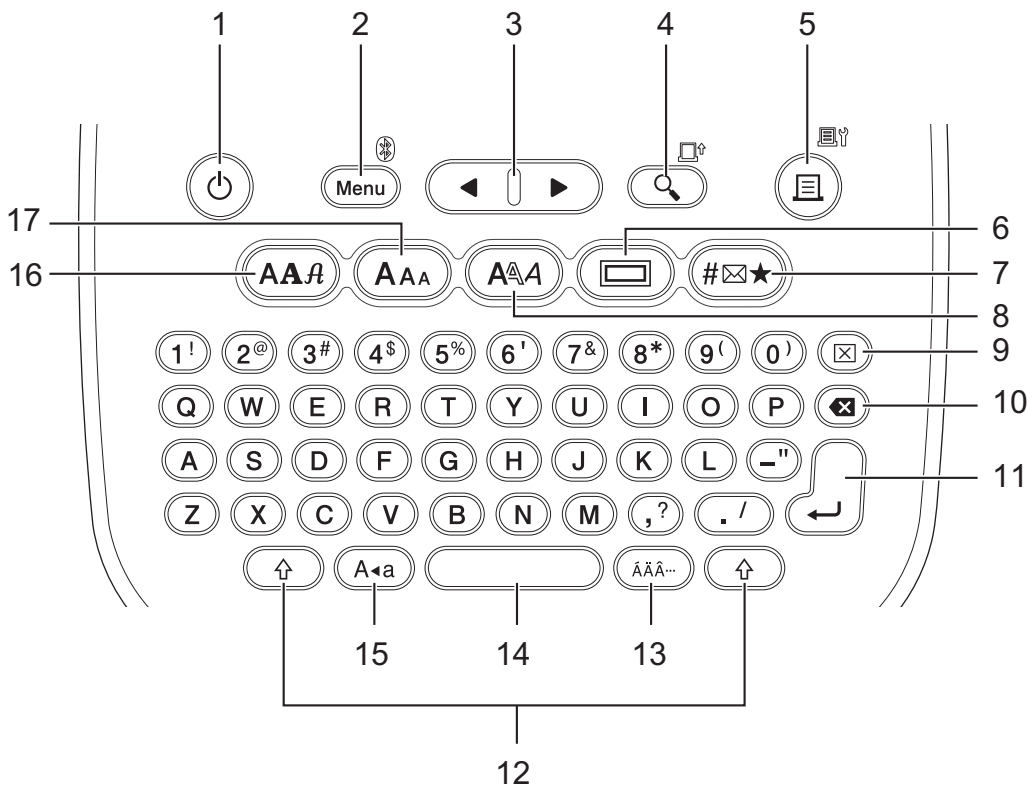

## 1. Power

Press to turn on or off the Label Maker.

## 2. Menu/Bluetooth (PT-N25BT)

Press to access the main menu.

To turn Bluetooth on or off, press the **Shift** key once, and then press the **Menu/Bluetooth** key.

## 3. Cursor

Press to move the cursor in the direction of the arrow.

---

#### 4. Preview/Feed

Press to view an image of the label before printing.

To feed the tape, press the **Shift** key once, and then press the **Preview/Feed** key.

#### 5. Print/Print Options

Press to print.

To set Print Options, press the **Shift** key once, and then press the **Print/Print Options** key.

#### 6. Underline/Frame

Press to select an underline or a frame.

#### 7. Symbol

Press to select and insert a symbol from the symbols menus.

#### 8. Character Style

Press to select a character style.

#### 9. Clear

Press to clear all text and format settings.

#### 10. Backspace

Press to delete any character to the left of the cursor.

#### 11. Enter

Press to confirm your selection.

#### 12. Shift

Press this key before pressing a letter or number key to type an uppercase letter or the symbol marked on the number key.

To move the cursor to the beginning of your text, press the **Shift** key once, and then press the ◀ key.

To move the cursor to the end of your text, press the **Shift** key once, and then press the ▶ key.

#### 13. Accent

Press to select an accented character.

#### 14. Space

Press to insert a blank space.

Press to return to the default value.

#### 15. Caps

Press to use only uppercase letters (ALL CAPS mode).

#### 16. Font

Press to select a font.

#### 17. Character Size

Press to select a character size.



### Related Information

- [Set Up Your Label Maker](#)



## Insert Tape Cassette

Make sure the ink ribbon is not sagging.

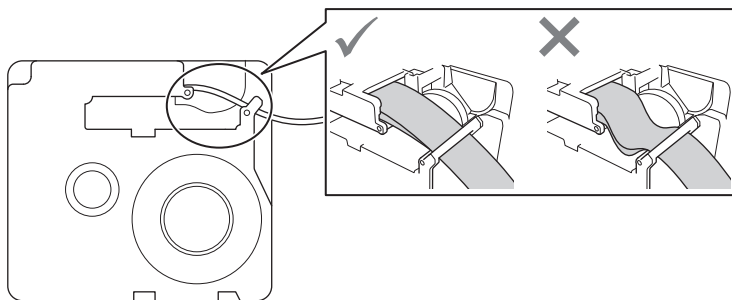

If the ink ribbon is sagging, wind the loose ink ribbon back onto the spool, as shown.

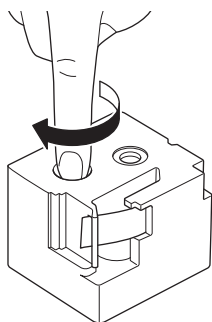

>> [PT-N10](#)

>> [PT-N20/PT-N25BT](#)

### PT-N10

1. Open the Tape Cassette Compartment Cover.

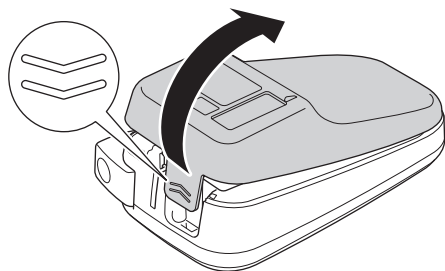

2. Insert the Tape Cassette as illustrated.

Make sure that the Tape Cassette fits securely between the clips (a) when it snaps into place.

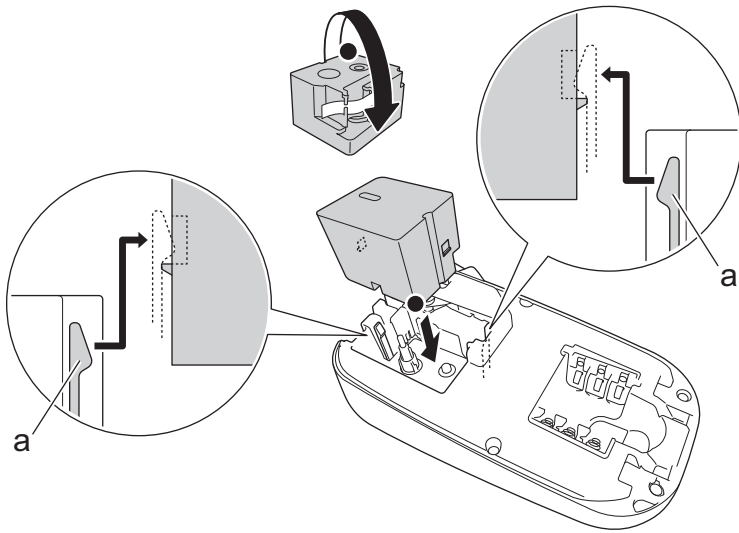

a. Clips

## NOTE

- When inserting the Tape Cassette, make sure that the tape does not catch on the Print Head.

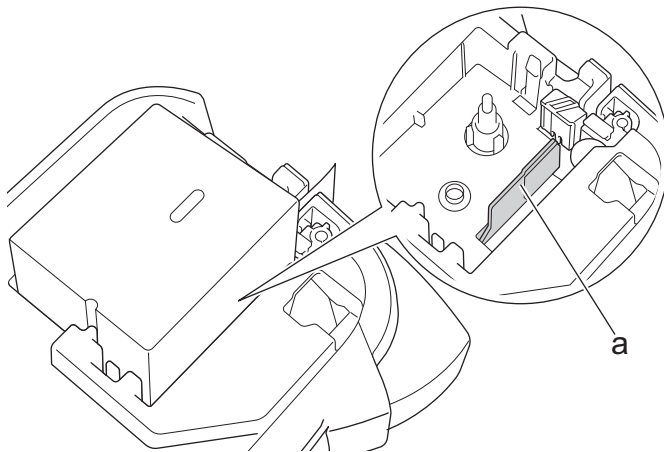

a. Print Head

- Make sure that the end of the tape exits through the Tape Exit Slot, as illustrated.

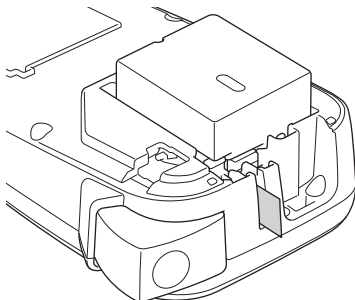

3. Close the Tape Cassette Compartment Cover.

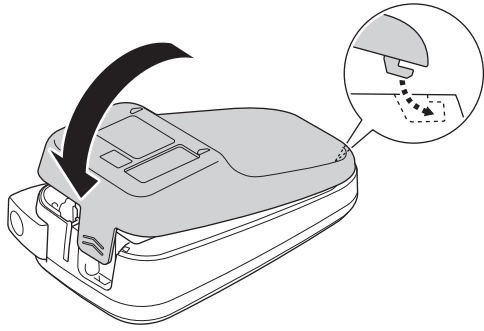

## PT-N20/PT-N25BT

1. Open the Tape Cassette Compartment Cover.

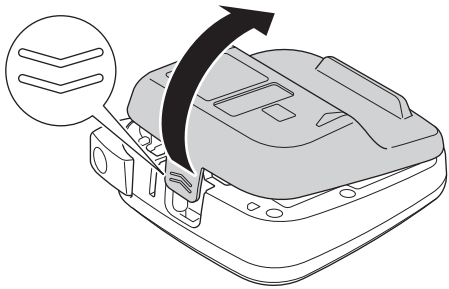

2. Insert the Tape Cassette as illustrated.

Make sure that the Tape Cassette fits securely between the clips (a) when it snaps into place.

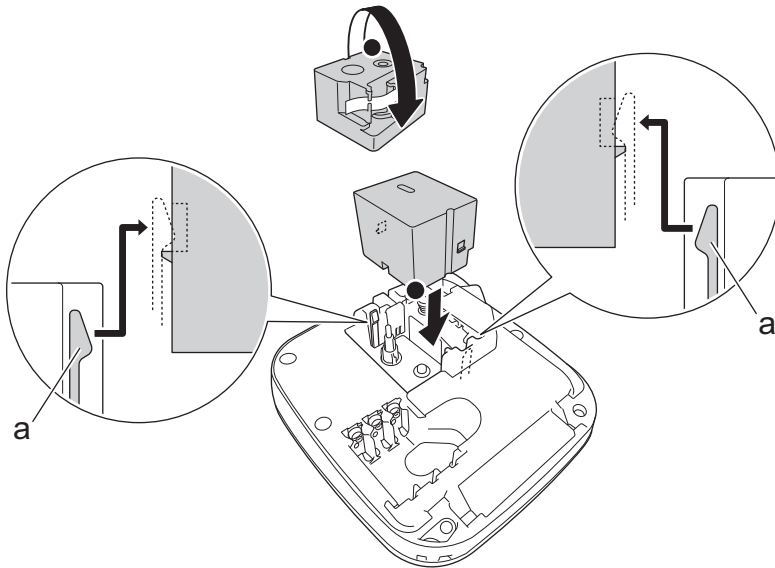

a. Clips

## NOTE

- When inserting the Tape Cassette, make sure that the tape does not catch on the Print Head.

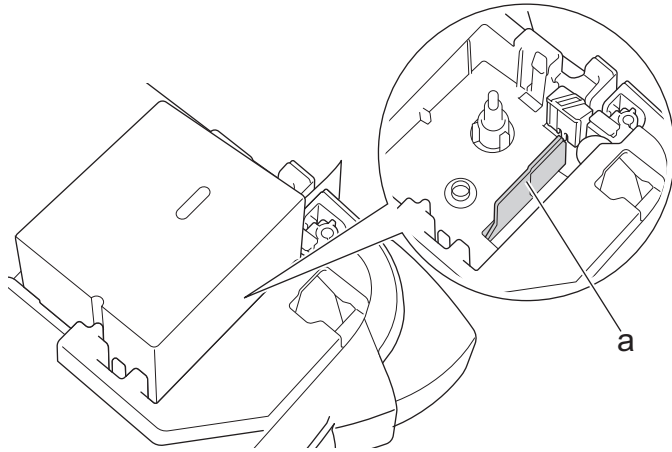

a. Print Head

- Make sure that the end of the tape exits through the Tape Exit Slot, as illustrated.

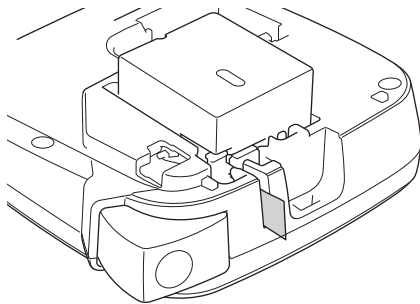

---

3. Close the Tape Cassette Compartment Cover.

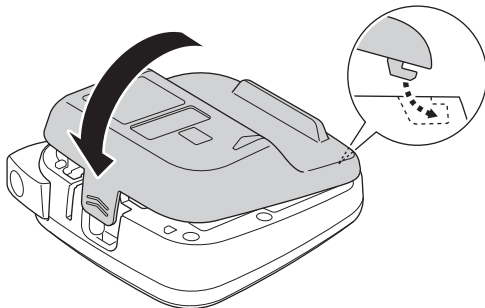

 **Related Information**

- [Set Up Your Label Maker](#)
-

## Install Batteries

(PT-N20/PT-N25BT) To ensure memory backup, we recommend using six new AAA Alkaline Batteries (LR03) along with the AC Adapter.

### NOTE

- Use only AAA Alkaline Batteries (LR03).
- When power is disconnected for more than two minutes, all text and format settings will be cleared. Any text files saved in the memory will also be cleared.
- Remove the batteries if you do not intend to use the Label Maker for an extended period of time.
- Dispose of the batteries at an appropriate collection point, not in the general waste stream. In addition, be sure to observe all applicable federal, state, and local regulations.
- To reduce the risk of battery fires, we recommend that you put tape over the battery terminals when storing loose batteries or disposing of them.

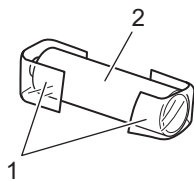

1. Cellophane tape
2. Alkaline battery

>> [PT-N10](#)

>> [PT-N20/PT-N25BT](#)

### PT-N10

1. Open the Tape Cassette Compartment Cover.

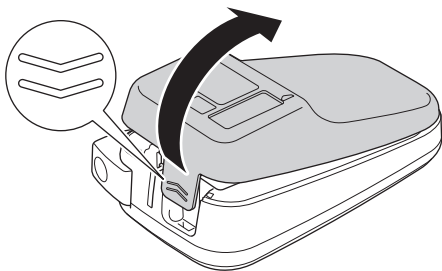

2. Install six new AAA alkaline batteries (LR03).  
Make sure they are installed in the correct direction.

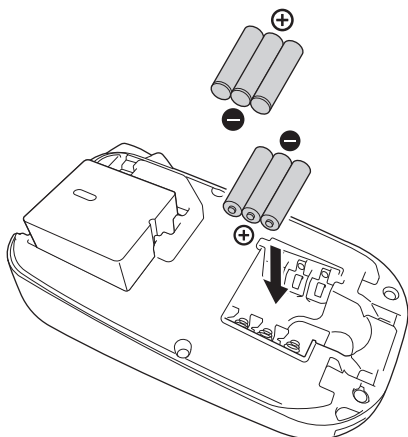

3. Close the Tape Cassette Compartment Cover.

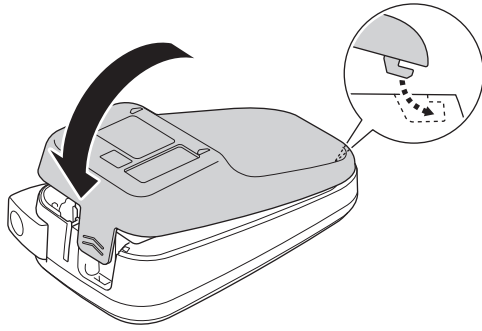

To remove the batteries, reverse the installation procedure.

## PT-N20/PT-N25BT

1. Open the Tape Cassette Compartment Cover.

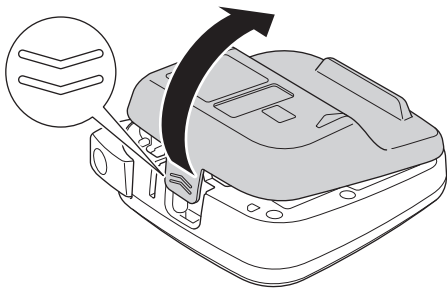

2. Install six new AAA alkaline batteries (LR03).  
Make sure they are installed in the correct direction.

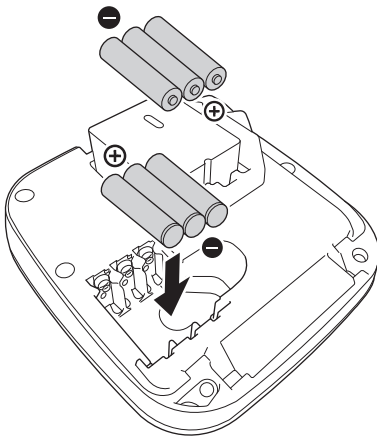

3. Close the Tape Cassette Compartment Cover.

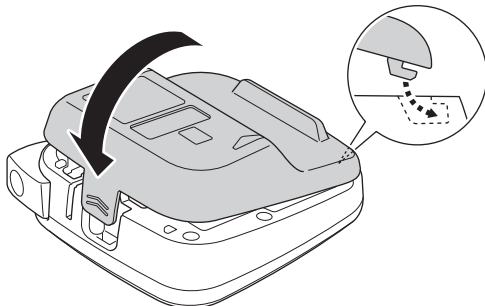

To remove the batteries, reverse the installation procedure.



## Related Information

- [Set Up Your Label Maker](#)
-

## Connect the AC Adapter

**Related Models:** PT-N20/PT-N25BT

If you plan to use an AC Adapter, we recommend using the Brother AC Adapter. This AC Adapter is configured to the exact voltage and current requirements of this Brother machine. Use of unauthorized AC Adapters may result in damage to your product.

1. Insert the AC Adapter cord into the AC Adapter Jack at the bottom of the Label Maker.

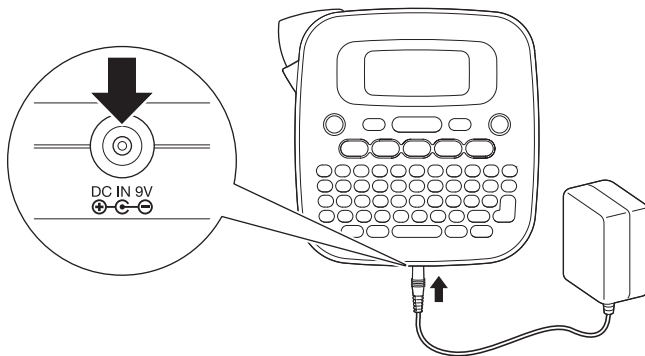



2. Insert the plug into the nearest standard electrical outlet.

### Related Information

- [Set Up Your Label Maker](#)



## Turn the Label Maker On/Off

1. To turn on the Label Maker, press .
2. To turn off the Label Maker, press and hold .

- PT-N10

Your Label Maker has a powersaving function that automatically turns it off if no key is pressed within five minutes.

- PT-N20/PT-N25BT

Your Label Maker has a powersaving function.

When the Label Maker is inactive, the power will automatically turn off after the time shown in the table below has passed.

Model	When Using Batteries	When Using an AC Adapter
PT-N20	5 minutes	5 minutes
PT-N25BT	10 minutes	20 minutes

When the following operations are performed, the time count is cleared:

- PT-N10:
  - Any key is pressed.
- PT-N20:
  - Any key is pressed.
  - The AC Adapter is disconnected and then reconnected.
- PT-N25BT:
  - Any key is pressed.
  - The AC Adapter is disconnected and then reconnected.
  - Any data is received.
  - The Label Maker is switched to Bluetooth pairing mode.



### Related Information

- [Set Up Your Label Maker](#)

## Set Language



>> PT-N10

>> PT-N20/PT-N25BT

### PT-N10

When you turn on the Label Maker for the first time, the language selection screen appears. Select a language by pressing ◀ or ▶, and then press .



To change the language at any time, follow these steps:

1. Press .
2. Press ◀ or ▶ to display the [Language] option, and then press .
3. Press ◀ or ▶ to select your language, and then press .

### PT-N20/PT-N25BT

When you turn on the Label Maker for the first time, the language selection screen appears. Select a language by pressing ◀ or ▶, and then press .

To change the language at any time, follow these steps:

1. Press .
2. Press ◀ or ▶ to display the [Language] option, and then press .
3. Press ◀ or ▶ to select your language, and then press .



### Related Information



- [Set Up Your Label Maker](#)

## Set Measurement Units



>> PT-N10

>> PT-N20/PT-N25BT

### PT-N10

1. Press .
2. Press ◀ or ▶ to display the [Unit] option, and then press .
3. Press ◀ or ▶ to select the [inch] or [mm] option, and then press .

### PT-N20/PT-N25BT

1. Press .
2. Press ◀ or ▶ to display the [Unit] option, and then press .
3. Press ◀ or ▶ to select the [inch] or [mm] option, and then press .







### Related Information



- [Set Up Your Label Maker](#)

## Enable or Disable Bluetooth

Related Models: PT-N25BT

1. Press .
2. Press ◀ or ▶ to display the [Bluetooth] option, and then press .
3. Press ◀ or ▶ to display the [Bluetooth On/Off] option, and then press .
4. Press ◀ or ▶ to select the [On] or [Off] option, and then press .



You can also enable or disable Bluetooth by pressing  once, and then  when the Home Screen is displayed.



### Related Information

- [Set Up Your Label Maker](#)
  - [LED Patterns and Indications](#)

## LED Patterns and Indications

Related Models: PT-N25BT

The Bluetooth LED is lit or flashes to indicate the printer's Bluetooth status.

Bluetooth LED Indicator	Description
Lit	Bluetooth is on, and the Label Maker is performing one of the following operations: <ul style="list-style-type: none"><li>• Printing</li><li>• Receiving data</li><li>• Feeding tape</li><li>• Transferring data</li><li>• Boot mode</li><li>• Bluetooth writing mode</li></ul>
Flashing (Once every four seconds)	Bluetooth is on, and the Label Maker is waiting for or processing data.
Flashing (Once every second)	Pairing with Bluetooth
Flashing (Once every 0.6 second)	System error



### Related Information

- [Enable or Disable Bluetooth](#)

## Feed Tape



>> [PT-N10](#)

>> [PT-N20/PT-N25BT](#)

### PT-N10

Press  and  simultaneously.

### PT-N20/PT-N25BT

Press  once, and then press .



### Related Information

- [Set Up Your Label Maker](#)

## Adjust LCD Contrast



To view the LCD more clearly, adjust the contrast.

The LCD Contrast default setting is [0].



>> [PT-N10](#)

>> [PT-N20/PT-N25BT](#)

### PT-N10

1. Press .
2. Press ◀ or ▶ to display the [LCD Contrast] option, and then press .
3. Press ◀ or ▶ to select your preference, [-2 - +2], and then press .

### PT-N20/PT-N25BT

1. Press .
2. Press ◀ or ▶ to display the [LCD Contrast] option, and then press .
3. Press ◀ or ▶ to select your preference, [-2 - +2], and then press .



### Related Information

- [Set Up Your Label Maker](#)

## Edit a Label

- [Add Text to Your Label](#)
- [Make a Two-Line Label](#)
- [Delete Text](#)
- [Enter Symbols](#)
- [Enter Accented Characters](#)
- [Set Character Attributes](#)
- [Set Label Length](#)
- [Set Underline or Frame](#)



## Add Text to Your Label

Type the text or symbols you want (up to 80 alphanumeric characters, including spaces and punctuation marks).



### Related Information

- [Edit a Label](#)
-

## Make a Two-Line Label

You can have up to two lines in your labels.

>> [PT-N10](#)

>> [PT-N20/PT-N25BT](#)

### PT-N10

1. When finished typing the first line of text, make sure the cursor is at the end of the current line.
2. Press  to create the second line.

Line 1

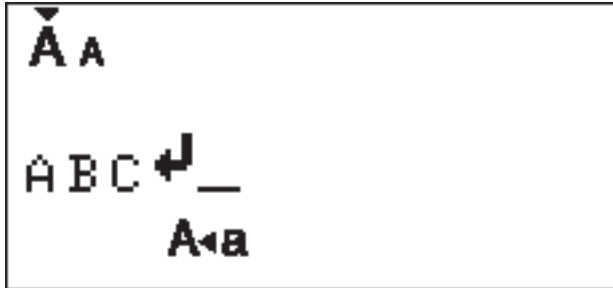

3. Enter the text in the second line, and then press .

Line 2



Printed Label Result



### PT-N20/PT-N25BT

1. When finished typing the first line of text, make sure the cursor is at the end of the current line.
2. Press  to create the second line.

Line 1

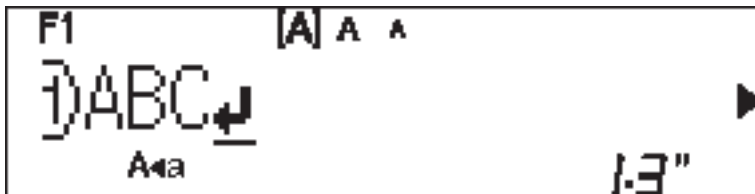

3. Enter the text in the second line, and then press .

Line 2

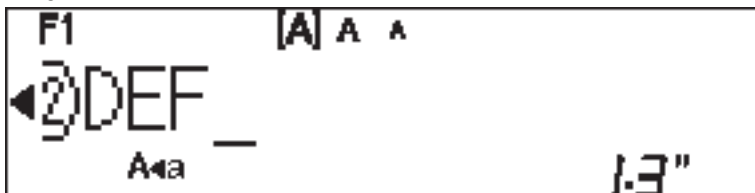

---

**Printed Label Result**

ABC DEF
------------



**Related Information**

- [Edit a Label](#)
-

## Delete Text

>> [PT-N10](#)

>> [PT-N20/PT-N25BT](#)

### PT-N10



Do one of the following:

- To delete one character at a time:

Press .

- To delete all text at the same time:

1. Press  and  simultaneously.

2. Press  or  to display the [Text Only] option, and then press .

- To delete all text and all format settings:

1. Press  and  simultaneously.

2. Press  or  to display the [Text&Format] option, and then press .

### PT-N20/PT-N25BT



Do one of the following:

- To delete one character at a time:

Press .



- To delete all text at the same time:

1. Press .

2. Press  or  to display the [Text Only] option, and then press .

- To delete all text and all format settings:

1. Press .

2. Press  or  to display the [Text&Format] option, and then press .

### Related Information

- [Edit a Label](#)

## Enter Symbols

- [Enter Symbols Using the Symbol Function](#)
- [Print the Pictograph List](#)
- [Symbol Options](#)





## Enter Symbols Using the Symbol Function

For a list of all symbols, see *Related Topics*: Symbol Options.

>> [PT-N10](#)

>> [PT-N20/PT-N25BT](#)

### PT-N10

1. Press .
2. Press ◀ or ▶ to select the [Basic] or [Pictograph] option, and then press .
3. Do one of the following:
  - If you selected the [Basic] option, press  to select a group.
  - If you selected the [Pictograph] option, press ◀ or ▶ to select a category, and then press .
4. Press ◀ or ▶ to select a symbol, and then press .



Pictographs are displayed on the LCD with the corresponding alphabet and number.





### PT-N20/PT-N25BT

1. Press .
2. Press ◀ or ▶ to select the [History], [Basic] or [Pictograph] option, and then press .



The [History] option is not displayed when you use the **Symbol** key for the first time. After using the **Symbol** key, you can view the Symbol History when you select the [History] option. The Symbol History displays up to seven recently used symbols.

3. If you selected the [Basic] or [Pictograph] option, press ◀ or ▶ to select a category, and then press .
4. Press ◀ or ▶ to select a symbol, and then press .

### ✓ Related Information



- [Enter Symbols](#)

#### Related Topics:

- [Symbol Options](#)

## Print the Pictograph List

Related Models: PT-N10

1. Press .
2. Press ◀ or ▶ to display the [Print List] option, and then press .
3. Press  to confirm.



### Related Information

- [Enter Symbols](#)

## Symbol Options

>> PT-N10

>> PT-N20/PT-N25BT

### PT-N10

[Basic]

01	.	,	:	;	"	'	•
02	@	-	&	~	_	\	/
03	#	%	?	!	¿	¡	*
04	(	)	[	]	<	>	
05	➔	➔	⬆	⬇	↔	↕	↔
06	+	-	×	÷	±	=	
07	\$	¢	€	£	¥	°	
08	●	○	■	□	▲	△	▼
09	▽	★	☆	♠	♠	♥	♥
10	◆	◇	♣	♣	?	?	+
11	♀	♂	♂	♀	♿	🍴	🗑️
12	♻️	🚫	⊖	☠️	🔥	☀️	☂️
13	❄️	✓	📎	✂️	📎	🕒	🔒
14	☎️	📱	✉️	🖥️	🧪	🏥	📄
15	🐱	🖥️	👉	🐘	🐘	🐌	🐾
16	🍏	🍇	🍷	🍺	☕	🍰	🍔
17	🎵	🎶	🎁	♣️	💞	♥️	🎬



To display the next group of symbols, press (#☒★).



[Pictograph]

	1	2	3	4	5	6	7
A							
B							
C							
D							
E							
F							
G							
H							
I							
J							
K							
L							
O							



To select the image you need, press the corresponding category button (A to O), and then use the ◀▶ keys.

**PT-N20/PT-N25BT**















































































[Basic]

Category	Symbols
Punctuation	. , : ; " ' • @ _ & ~ _ \ / # % ? ! ? i *
Brackets	( ) [ ] < >
Arrows	

Category	Symbols
Mathematics	+ - × ÷ ± =
Units	\$ ¢ € £ ¥ ¢
Shapes	● ○ ■ □ ▲ △ ▼ ▽ ★ ☆ ♠ ♡ ♥ ♣ ◆ ◇ ♣ ♣ ? ! +

[Pictograph]

Category	Symbols
Emojis	😊 😄 😍 😞 😴 👍 ✌️
Family	👨 👩 👶 👧 👦 👪 👶
Fashion	👕 🧥 🩲 👚 👙 🖊️ 🧥 👖 🧦 🧤 🧤 👟 👜 🧢
Accessories	🕶️ 📁 📄 📁 💄 💍 💎 👑
Food	🍏 🍇 🍓 🍋 🍒 🍍 🍅 🌽 🍖 🍔 🍕 🍪 🍰 🍷 🍰 🍷 🍺 ☕
Kitchen	🍽️ 🥤 🥤 🌶️ 🥤 🌿 🍋
Healthcare	🧼 🧪 🏥 🩺 🧴 💊 🧴
Signs	♀️ ♂️ 🚶 🚶 ♿️ 🍴 🗑️ ♻️ 🚫 🚫 ☠️ 🔥 ⚠️ ⚠️
Stationery	✉️ ✂️ 📎 ⏳ 📎 🕒 📖 📖 📁 🔑 🔒 📄 ✓
Gadgets	📞 📱 🖥️ 📱 🎮 🔌 📷 🎧 📢 🗄️

Category	Symbols
Hobbies	        
Vehicles	     
Weather	    
Garden	         
Animals	                    
Fun	              
Events	            

 **Related Information**



- [Enter Symbols](#)

## Enter Accented Characters

>> [PT-N10](#)

>> [PT-N20/PT-N25BT](#)



### PT-N10

1. Enter the character you want.
2. Press .
3. Press ◀ or ▶ to select an accented character, and then press .



- You can enter accented characters while in Caps mode.
- Another way of viewing the accent variations for any letter is to press and hold that letter key.

### PT-N20/PT-N25BT

1. Enter the character you want.
2. Press .
3. Press ◀ or ▶ to select an accented character, and then press .



- You can enter accented characters while in Caps mode.
- Another way of viewing the accent variations for any letter is to press and hold that letter key.

### Related Information

- [Edit a Label](#)
- [Accented Character Options](#)

## Accented Character Options

The accented characters displayed on the LCD depend on your language.

Character	Accented Characters
a	á à â ä æ ã å ä ä
A	Á À Â Ä Æ Ã Å Ä Å
c	ç ċ ċ
C	Ç Ć Ć
d	d' ð đ
D	Ď Ď
e	é è ê ë ě ě è ē
E	É È Ê Ë Ě Ě Ě Ě
g	g' ğ
G	Ĝ Ğ
i	í ì î ï ĵ ĵ ĵ
I	Í Ì Î Ï Ĵ Ĵ Ĵ
k	ķ
K	Ķ
l	ł ł ł ł
L	Ł Ł Ł Ł
n	ñ ñ ñ ñ
N	Ñ Ñ Ñ Ñ
o	ó ò ô ø ö õ œ ö
O	Ó Ò Ô Ø Ö Õ Œ Ö
r	ř ř ř
R	Ř Ř Ř
s	š š š š ß
S	Š Š Š Š ß
t	t' t þ
T	Ť Ť Þ

Character	Accented Characters
u	ú ù û ü ů ū ů
U	Ú Ù Û Ü Ů Ū Ů
y	ý ÿ
Y	Ý Ÿ
z	ž ź ž
Z	Ž Ź Ž



### Related Information

- [Enter Accented Characters](#)





## Set Character Attributes

When you set character attributes, they apply to all characters in your label.







>> [PT-N10](#)

>> [PT-N20/PT-N25BT](#)

### PT-N10

1. Type the text you want.
2. Press .
3. Press ◀ or ▶ to select an attribute, and then press .
4. Press ◀ or ▶ to set a value for that attribute, and then press .
5. Select another attribute to format, if needed. When finished, press  to print your label.

### PT-N20/PT-N25BT

1. Type the text you want.
2. Do one of the following:
  - To set the font, press .
  - To set the character size, press .
  - To set the character style, press .
  - To set the character width, press . Press ◀ or ▶ to select the [width] option, and then press .
3. Press ◀ or ▶ to set a value for that attribute, and then press .
4. Select another attribute to format, if needed. When finished, press  to print your label.

### Related Information

- [Edit a Label](#)
  - [Attribute Setting Options](#)

## Attribute Setting Options

### Font

Value	Result
Helsinki F1 (PT-N20/PT-N25BT)	A1
Brussels F2 (PT-N20/PT-N25BT)	A1
Berlin F3 (PT-N20/PT-N25BT)	<i>A1</i>

### Character Size

#### Available Sizes:

[Small], [Medium], [Large]

### Character Width

Value	Result
Normal	A
x 2	<b>A</b>
x 1/2	<i>A</i>

### Character Style

Value	Result
Normal	A
Bold	<b>A</b>
Outline (PT-N20/PT-N25BT)	A
Shadow	A
Italic	<i>A</i>
I+Bold	<b><i>A</i></b>
Vertical	A



### Related Information

- [Set Character Attributes](#)





## Set Label Length

Labels can be between 1.2" (30 mm) and 12.0" (300 mm) in length. When you select [Auto], the label length is automatically adjusted based on the amount of text it contains.

>> [PT-N10](#)



>> [PT-N20/PT-N25BT](#)

### PT-N10

1. Press .
2. Press ◀ or ▶ to select the [Label Length] option, and then press .
3. Press ◀ or ▶ to set a label length value, and then press .

If a specific label length has been selected,  is displayed on the LCD.

### PT-N20/PT-N25BT

1. Press .
2. Press ◀ or ▶ to select the [Label Length] option, and then press .
3. Press ◀ or ▶ to set a label length value, and then press .

If a specific label length has been selected,  is displayed on the LCD.



### Related Information

- [Edit a Label](#)

#### Related Topics:

- [Set Margins](#)



## Set Underline or Frame

You can set an underline style or a frame before or after typing your label text.



>> [PT-N10](#)

>> [PT-N20/PT-N25BT](#)

### PT-N10

1. Press .
2. Press ◀ or ▶ to select an underline or a frame, and then press .

### PT-N20/PT-N25BT

1. Press .
2. Press ◀ or ▶ to select an underline or a frame, and then press .

### ✓ Related Information











- [Edit a Label](#)
  - [Underline and Frame Options](#)

## Underline and Frame Options

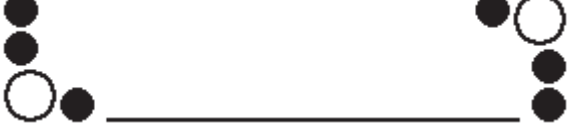







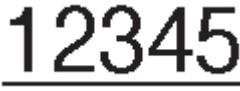

>> PT-N10

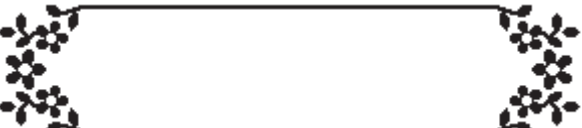

>> PT-N20/PT-N25BT

### PT-N10

Style	Underline/Frames
Underline	
Round	
Square	
Octagon	
Bubble	
Star	
Heart	
Flower	
Trip	
Unicorn	

**PT-N20/PT-N25BT**

Style	Underline/Frames
Underline	
Round	
Square	
Octagon	
Bubble	
Star	
Heart	
Flower	
Trip	
Unicorn	
Mermaid	
Peter Pan	

Style	Underline/Frames
Sweets	
Pet	
Decorative	



**Related Information**

- [Set Underline or Frame](#)

## Print Labels

- [Preview Labels](#)
- [Print Labels](#)
- [Set Margins](#)
- [Adjust the Label Length](#)
- [Adjust the Print Density](#)

## Preview Labels

You can preview labels before printing to make sure they are correct.

>> [PT-N10](#)

>> [PT-N20/PT-N25BT](#)

### PT-N10

Press .

The LCD displays all text and the label length (inch/mm), then returns to the original text.



Only text can be previewed. Font style, size, underline, frames, and other features cannot be previewed.

### PT-N20/PT-N25BT

Press .

The LCD displays an image of the label and the label length (inch/mm).



- Press ◀ or ▶ to scroll left or right in the preview image.
- The printed label may differ from the preview image due to the LCD resolution.



### Related Information

- [Print Labels](#)

## Print Labels

To cut your printed label, press the Tape Cutter Lever on the top left corner of the Label Maker when the message [Please Cut] appears on the LCD.

To save tape, multiple copies of the same label can be printed on a continuous piece of tape. Each label is separated by printed dots (:). Cut the labels at the : mark with scissors to separate them.



### NOTE

- To prevent damage to the tape, do not press the Tape Cutter Lever while the message [Please Wait] is displayed on the LCD.
- Do not pull the label when the Label Maker is ejecting it from the Tape Exit Slot. Doing so will cause the ink ribbon to be discharged with the tape, making the tape unusable.
- Do not block the Tape Exit Slot during printing. Doing so will cause the tape to jam.

>> [PT-N10](#)

>> [PT-N20/PT-N25BT](#)

### PT-N10



1. After creating your label, press .
2. Press ◀ or ▶ to change the number of copies, and then press  or .



- You can also specify the number of copies using the number keys.
- If you need only one label, press  twice.

- The label prints as many times as you specify. Each copy is separated by printed dots (:), which act as cutting guides.
- Cut along the printed dots (:) with scissors after the label prints. Each label length matches the value you set in the [Label Length] menu.
- If the printed label is too dark or too light, adjust the print density and reprint your label.

### PT-N20/PT-N25BT

1. After creating your label, press .
2. Press ◀ or ▶ to change the number of copies, and then press  or .



- You can also specify the number of copies using the number keys.
- If you need only one label, press  twice.

- The label prints as many times as you specify. Each copy is separated by printed dots (:), which act as cutting guides.
- Cut along the printed dots (:) with scissors after the label prints. Each label length matches the value you set in the [Label Length] menu.



### Related Information

- [Print Labels](#)
  - [Sequential Printing](#)



- 
- [Mirror Printing](#)

**Related Topics:**





- [Adjust the Print Density](#)
-

## Sequential Printing

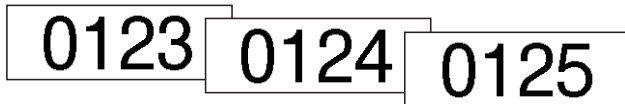
**Related Models:** PT-N20/PT-N25BT

You can print up to nine sequential labels at a time using auto-numbering. This feature allows you to automatically increase the initial number by one in each consecutive label.



1. Enter your starting number.
2. Press ◀ or ▶ to move the cursor to the digit you want to increase.
3. Press  and .
4. Press ◀ or ▶ to display the [Numbering] option, and then press .
5. Press ◀ or ▶ to select the end value of the serial number, and then press  or .

### Related Information







- [Print Labels](#)

## Mirror Printing

**Related Models:** PT-N20/PT-N25BT

Use clear tape when mirror printing, so the labels can be read correctly from the opposite side when attached to glass or other transparent surfaces.



1. Enter the text you want.
2. Press  and .
3. Press  or  to display the [Mirror] option, and then press .
4. Press  or  to confirm.

### Related Information

- [Print Labels](#)

## Set Margins



You can select the margin options, regardless of the label length.

For more information, see *Related Information: Margin Options*.



>> [PT-N10](#)

>> [PT-N20/PT-N25BT](#)

### PT-N10

1. Press .
2. Press ◀ or ▶ to display the [Margin] option, and then press .
3. Press ◀ or ▶ to select the [Small], [Medium], [Large], or [ChainPrint] option, and then press .

### PT-N20/PT-N25BT

1. Press .
2. Press ◀ or ▶ to display the [Margin] option, and then press .
3. Press ◀ or ▶ to select the [Small], [Medium], [Large], or [Chain Print] option, and then press .



### Related Information



- [Print Labels](#)
  - [Margin Options](#)

## Margin Options

This table shows how different margin options appear on labels.

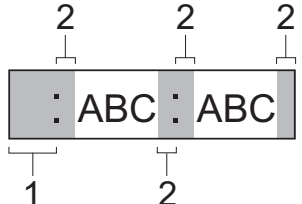
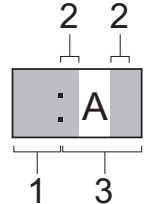
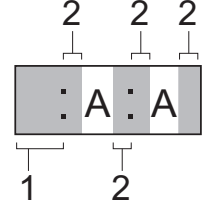
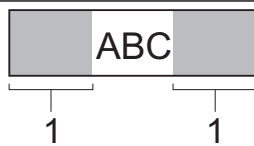
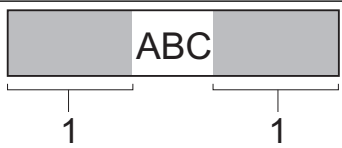
	Print area
	Margin

Setting	Description	Example
Small	The tape automatically feeds 0.4" (10.5 mm) first, and then each label is printed, leaving a margin of 0.15" (4 mm) before and after the text.	<ul style="list-style-type: none"> <li>When the label length is approximately 1.0" (26 mm) or more:                              <ol style="list-style-type: none"> <li>Approximately 0.4" (10.5 mm)</li> <li>0.15" (4 mm)</li> </ol> </li> <li>When the label length is approximately 1.0" (26 mm) or less                             <ul style="list-style-type: none"> <li>If printing a single label:                                      </li> <li>If printing multiple labels:                                      <ol style="list-style-type: none"> <li>Approximately 0.4" (10.5 mm)</li> <li>0.15" (4 mm)</li> <li>Approximately 0.6" (15.5 mm)</li> </ol> </li> </ul> </li> </ul>
Medium	Each label has a margin of 0.47" (12 mm) before and after the text.	 <ol style="list-style-type: none"> <li>Approximately 0.47" (12 mm)</li> </ol>
Large	Each label has a margin of 0.78" (20 mm) before and after the text.	 <ol style="list-style-type: none"> <li>Approximately 0.78" (20 mm)</li> </ol>

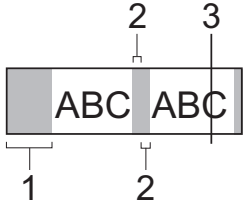
Setting	Description	Example
Chain Print <sup>1</sup>	<ul style="list-style-type: none"> <li>• Select this setting when printing several labels with minimum margins.</li> <li>• The tape automatically feeds 0.4" (10.5 mm) first, and then each label is printed, leaving a margin of 0.08" (2 mm) before and after the text.</li> <li>• The cut position is set in the middle of the printing area after the last label is printed. When the message <code>Feed OK?</code> appears on the LCD, press  /  to feed the tape, otherwise part of the text may get cut off. Do not try to pull the tape as this may damage the Tape Cassette.</li> </ul> <p>Press  to return to the text entry screen.</p>	 <ol style="list-style-type: none"> <li>1. Approximately 0.4" (10.5 mm)</li> <li>2. 0.08" (2 mm)</li> <li>3. Tape stop position</li> </ol>

<sup>1</sup> (PT-N25BT) The size of the margin is different when Chain Print is set on the printer and when Chain Print is set on the Brother P-touch Design&Print 2 app. Chain Print set on the printer prints a slightly smaller margin.



## Related Information

- [Set Margins](#)

## Adjust the Label Length

Related Models: PT-N10

When the Tape Cassette is almost empty, the printed label length may be less accurate. In this case, adjust the label length manually.



There are 11 levels for this setting: -5, -4, -3, -2, -1, 0, +1, +2, +3, +4, +5

Approximately 1% of the total label length is adjusted by one level.

1. Press **Menu**.
2. Press **◀** or **▶** to display the [AdjustLength] option, and then press **↵**.
3. Press **◀** or **▶** to display the [-5 - +5] option, and then press **↵**.





### Related Information

- [Print Labels](#)

## Adjust the Print Density

Related Models: PT-N10

1. Press .
2. Press ◀ or ▶ to display the [PrintDensity] option, and then press .
3. Press ◀ or ▶ to select the number you want from [Set 1 - 4], and then press .

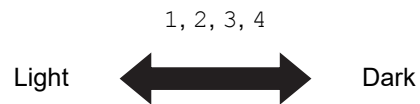

### Related Information

- [Print Labels](#)



## Use the File Memory

- [Save Label Files](#)
- [Print or Open a Saved Label](#)





## Save Label Files

You can save up to 10 labels and recall them for printing at a later date. Each label file can contain a maximum of 80 characters. You can also edit and overwrite saved labels.

>> [PT-N10](#)

>> [PT-N20/PT-N25BT](#)





### PT-N10

1. Enter the text and format your label.
2. Press .
3. Press ◀ or ▶ to display the [File] option, and then press .
4. Press ◀ or ▶ to display the [Save] option, and then press .
5. Press ◀ or ▶ to select a file number, and then press .



If you see the message [Overwrite?] appears on the LCD, press the ◀ or ▶ keys to either assign a different number to your file or to overwrite the existing file that currently uses this number.

### PT-N20/PT-N25BT

1. Enter the text and format your label.
2. Press .
3. Press ◀ or ▶ to display the [File] option, and then press .
4. Press ◀ or ▶ to display the [Save] option, and then press .
5. Press ◀ or ▶ to select a file number, and then press .



If you see the message [Overwrite OK?] appears on the LCD, press the ◀ or ▶ keys to either assign a different number to your file or to overwrite the existing file that currently uses this number.



### Related Information



- [Use the File Memory](#)







## Print or Open a Saved Label

>> PT-N10



>> PT-N20/PT-N25BT







### PT-N10

1. Press .
2. Press ◀ or ▶ to display the [File] option, and then press .
3. Do one of the following:

Option	Description
Open	<ol style="list-style-type: none"><li>a. Press ◀ or ▶ to display the Open option, and then press .</li><li>b. Press ◀ or ▶ to select a file, and then press .</li></ol>
Print	<ol style="list-style-type: none"><li>a. Press ◀ or ▶ to display the Print option, and then press .</li><li>b. Press ◀ or ▶ to select a file, and then press .</li><li>c. Press ◀ or ▶ to change the number of copies, and then press  or .</li></ol>

### PT-N20/PT-N25BT

1. Press .
2. Press ◀ or ▶ to display the [File] option, and then press .
3. Do one of the following:

Option	Description
Open	<ol style="list-style-type: none"><li>a. Press ◀ or ▶ to display the Open option, and then press .</li><li>b. Press ◀ or ▶ to select a file, and then press .</li></ol>
Print	<ol style="list-style-type: none"><li>a. Press ◀ or ▶ to display the Print option, and then press .</li><li>b. Press ◀ or ▶ to select a file, and then press .</li><li>c. Press ◀ or ▶ to change the number of copies, and then press  or .</li></ol>

### ✓ Related Information

- [Use the File Memory](#)

## Print Labels Using Mobile Devices

**Related Models:** PT-N25BT

- [Install Brother P-touch Design&Print 2 App](#)
- [Connect the Printer to a Mobile Device Using Bluetooth](#)
- [Create Labels and Print Them Using a Mobile Device](#)

## Install Brother P-touch Design&Print 2 App

**Related Models:** PT-N25BT

Use the Brother P-touch Design&Print 2 app to create labels and print them directly from your iPhone, iPad, and Android™ mobile devices.

App	Features
Brother P-touch Design&Print 2	Design and create stylish labels for work or home. 

For more information about the mobile apps available for your printer, visit <https://support.brother.com/g/d/f5f9>.



### Related Information

- [Print Labels Using Mobile Devices](#)

## Connect the Printer to a Mobile Device Using Bluetooth

**Related Models:** PT-N25BT

When launching the Brother P-touch Design&Print 2 app for the first time, you must connect the printer to your mobile device.

1. Turn on the Label Maker.
2. Set the printer's Bluetooth setting to On.
  - a. Press **Menu**.
  - b. Press ◀ or ▶ to display the [Bluetooth] option, and then press .
  - c. Press ◀ or ▶ to display the [Bluetooth On/Off] option, and then press .
  - d. Press ◀ or ▶ to select [On], and then press .
3. Enable Bluetooth in your mobile device's Settings screen.



Do not select your Brother printer from your mobile device's Bluetooth screen. You will select your printer using the app in the next step.

4. Start Brother P-touch Design&Print 2 on your mobile device.
5. When the app launches, tap your printer in the printer selection screen in the app.  
Your printer's Bluetooth LED blinks in green.

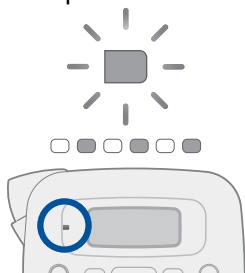

### Related Information

- [Print Labels Using Mobile Devices](#)

## Create Labels and Print Them Using a Mobile Device

**Related Models:** PT-N25BT

Make sure the Label Maker is connected to your mobile device via Bluetooth.

1. Start the label printing app on your mobile device.
2. Select a label template or design.



You can also select a previously designed label or image and print it.

3. Select the print menu in the label printing app and print your label.



### Related Information

- [Print Labels Using Mobile Devices](#)

## Routine Maintenance

- [Maintenance](#)



## Maintenance

- PT-N10  
Always remove the batteries before performing routine maintenance of the Label Maker.
- PT-N20/PT-N25BT  
Always remove the batteries and disconnect the AC Adapter before performing routine maintenance of the Label Maker.

- >> [Clean the Unit](#)
- >> [Clean the Print Head and Tape Exit Slot](#)
- >> [Clean the Cutter Blade](#)
- >> [Turn the Cutter Board Around](#)

### Clean the Unit

1. Wipe any dust and marks from the Label Maker using a soft, dry cloth.
2. Use a slightly dampened cloth on difficult to remove marks.



Do not use paint thinner, benzene, alcohol or any other organic solvent. These may deform or damage the case of your Label Maker.

### Clean the Print Head and Tape Exit Slot

Streaks or poor quality printed labels, or tape does not feed correctly generally indicate that the Print Head and Tape Exit Slot are dirty.

Clean them using a cotton swab.

- PT-N10

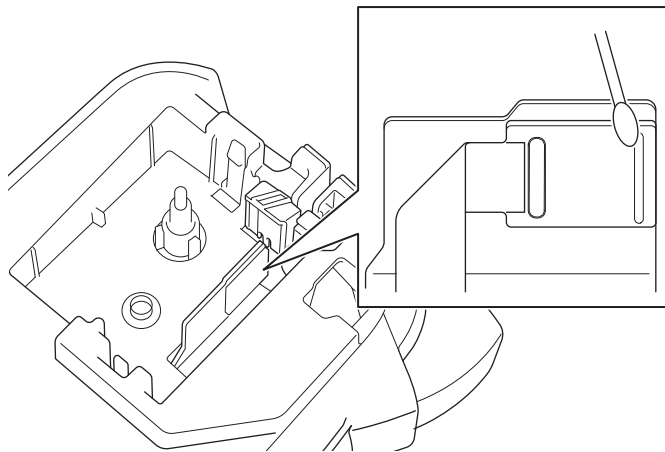

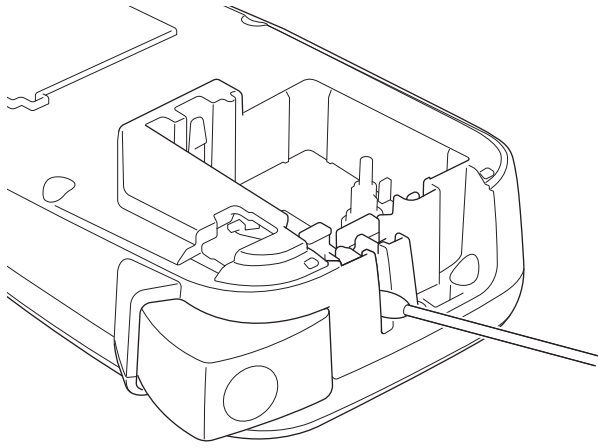

- PT-N20/PT-N25BT

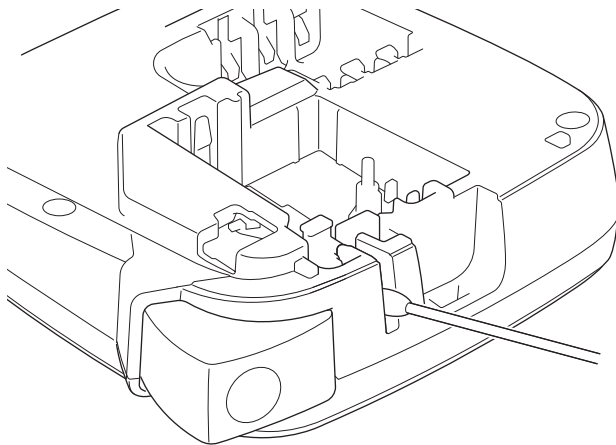
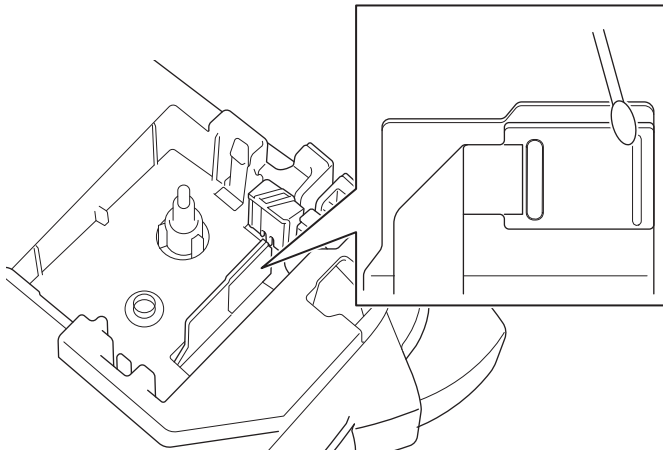

Do not touch the Print Head directly with your bare hands.

### Clean the Cutter Blade

Tape adhesive can build up on the Cutter Blade after repeated use, which may result in poor cut quality. If the Cutter Blade does not cut the tape cleanly, remove the residue with a piece of Letter or A4 paper:

1. Fold a piece of paper three times, as illustrated.

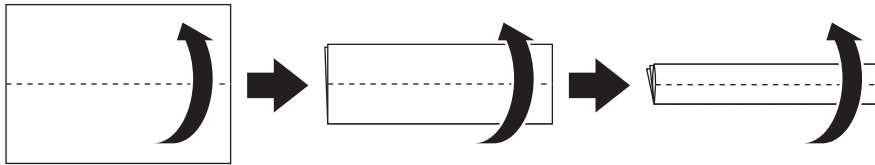

2. Open the Tape Cassette Compartment Cover and place the folded paper between the Cutter Board and the Tape Cutter.

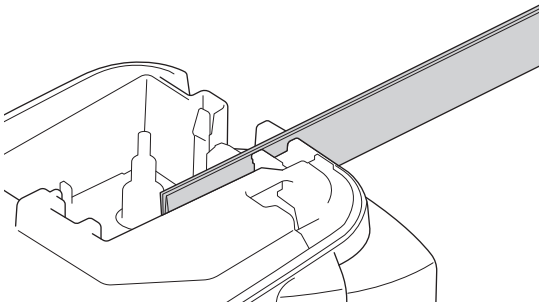

3. Close the Tape Cassette Compartment Cover and press the Tape Cutter Lever three times. This cleans the blade and cuts the paper.

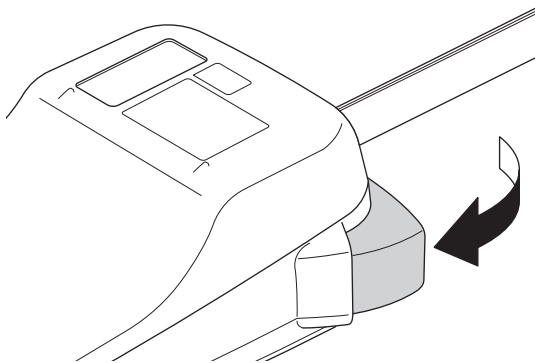

4. Open the Tape Cassette Compartment Cover and remove the paper.

If the cut quality remains poor, repeat these steps.

### Turn the Cutter Board Around

The Cutter Blade becomes blunt after repetitive use and cannot cut the tape cleanly. Turning the Cutter Board around allows you to continue cutting using the other side. The Cutter Board can be turned only once to improve cutting.

- PT-N10

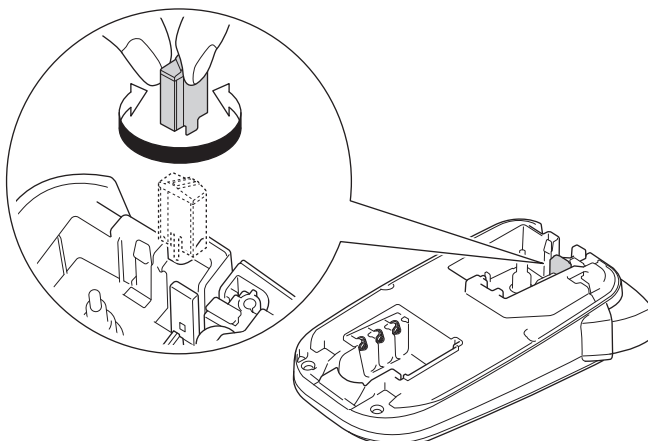

---

- PT-N20/PT-N25BT

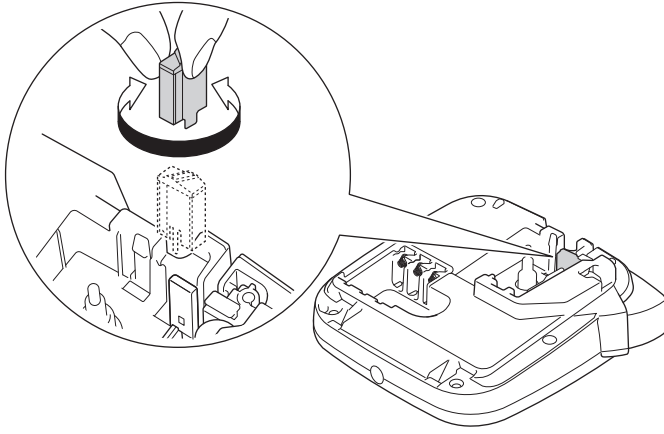

If the problem continues, contact Brother Customer Service or your local Brother dealer.



### **Related Information**

- [Routine Maintenance](#)
-



## Troubleshooting



- [If You Are Having Difficulty with Your Label Maker](#)
- [Error and Maintenance Messages](#)
- [Check the Version Information](#)
- [Reset the Label Maker](#)

## If You Are Having Difficulty with Your Label Maker

This chapter explains how to resolve typical problems you may encounter when using the Label Maker.

If you still have problems, see *Related Information*. If after reading the topics you are unable to resolve the problem, visit the Brother support website at [support.brother.com/faqs](http://support.brother.com/faqs).

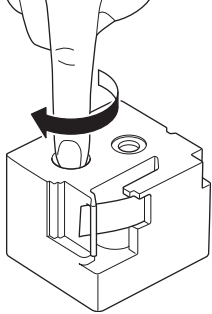
Problem	Solution
The Label Maker does not print.	<ul style="list-style-type: none"> <li>• Check that the Tape Cassette is inserted correctly.</li> <li>• (For USA) If the Tape Cassette is empty, replace it. To order supplies and accessories, visit <a href="http://www.brother-usa.com">www.brother-usa.com</a>.</li> <li>• (For Canada) If the Tape Cassette is empty, replace it. To order supplies and accessories, visit <a href="http://www.brother.ca">www.brother.ca</a>.</li> <li>• Check that the Tape Cassette Compartment Cover is securely closed.</li> <li>• Check that the Label Maker is on.</li> <li>• If the Print Head is dirty, clean it with a cotton swab.</li> <li>• PT-N25BT: Confirm the following:               <ul style="list-style-type: none"> <li>- Your mobile device's Bluetooth setting is on.</li> <li>- The Label Maker is connected to your mobile device via Bluetooth.</li> <li>- The Label Maker is selected in the Brother P-touch Design&amp;Print 2 app.</li> <li>- The Label Maker is not paired with another device.</li> <li>- The Label Maker and your mobile device are within range to communicate.</li> <li>- No devices that emit radio waves (for example, a microwave oven) are located nearby.</li> </ul> </li> </ul>
<ul style="list-style-type: none"> <li>• The tape does not feed correctly.</li> <li>• The tape gets stuck inside the Label Maker.</li> </ul>	<ul style="list-style-type: none"> <li>• If the tape is bent, cut off the bent section.</li> <li>• If the tape is jammed, remove the Tape Cassette, remove the jammed tape, and then cut off any damaged tape. To avoid tape jams, clean the Tape Cutter and Tape Exit Slot. See <i>Related Topics</i>.</li> <li>• Check that the end of the tape exits through the Tape Guide.</li> <li>• Confirm that the tape is pointed at the Tape Exit Slot.</li> <li>• Remove the Tape Cassette and reinstall it.</li> <li>• Make sure that the Tape Cassette fits securely between the clips when it snaps into place.</li> </ul>
An error occurred when using a mobile app.	Go to your mobile application's settings menu and select <b>Support &gt; FAQs &amp; Troubleshooting</b> .
The LCD is not responding.	<ul style="list-style-type: none"> <li>• PT-N10: Remove the batteries, press and hold  for a few seconds, and then wait for at least 10 minutes.</li> <li>• PT-N20/PT-N25BT: Disconnect the AC Adapter, remove the batteries, press and hold  for a few seconds, and then wait for at least 10 minutes.</li> <li>• Reset the internal memory to the factory settings. For more information, see <i>Related Topics</i>: Reset the Label Maker.</li> </ul>
The LCD remains blank after turning the power on.	<ul style="list-style-type: none"> <li>• PT-N10: Check that the batteries are correctly installed.</li> <li>• PT-N20/PT-N25BT: Check that the batteries are correctly installed and that the AC Adapter is correctly connected.</li> </ul>
The LCD messages are displayed in a foreign language.	Set the LCD language you want. For more information, see <i>Related Topics</i> : Set Language.
The Label Maker stops while printing a label.	<ul style="list-style-type: none"> <li>• If striped tape is visible, this indicates that you have reached the end of the tape. Replace the Tape Cassette.</li> <li>• PT-N10: Replace all batteries.</li> <li>• PT-N20/PT-N25BT: Replace all batteries or connect the AC Adapter directly to the Label Maker.</li> </ul>

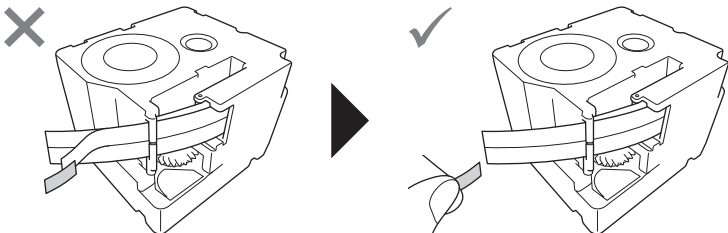
Problem	Solution
Previously saved label files are not available.	<ul style="list-style-type: none"> <li>PT-N10: All files saved in the internal memory will be deleted when the batteries are low or are depleted.</li> <li>PT-N20/PT-N25BT: All files saved in the internal memory will be deleted when the batteries are low, depleted, or the AC Adapter is disconnected.</li> </ul>
The ink ribbon is separated from the ink roller.	<p>If the ink ribbon is damaged, replace the Tape Cassette. If it is not damaged, leave the tape uncut and carefully remove the Tape Cassette, and then wind the loose ink ribbon back onto the spool.</p> <p>For more information, see <i>Related Topics</i>: Insert Tape Cassette.</p> 
I do not know the version number of the firmware for the Label Maker. (PT-N25BT)	<p>You can confirm the firmware version number and other information on the LCD.</p> <p>For more information, see <i>Related Topics</i>: Check the Version Information.</p>
When the label is printed, there is too much space (wide margin) on both sides of the text.	<p>Due to its design, the Label Maker feeds some margin each time it prints a new label. The margin length depends on "Margin Options" setting. Select the <i>Small</i> or <i>Chain Print</i> option for smaller margins.</p> <p>For more information, see <i>Related Topics</i>: Margin Options.</p>
The font size cannot be increased.	<p>The font is already the maximum size for the width of the label, or the label length has been set, so there is a limit on the font size to prevent exceeding the set length.</p>
When multiple labels are printed, the last label is cut incorrectly.	<p>When <i>Chain Print</i> is enabled, feed the tape to eject the last printed label, and then press the Tape Cutter Lever to cut the label manually.</p>
The Label Maker does not operate normally.	<ul style="list-style-type: none"> <li>PT-N10: Remove the batteries, press and hold  for a few seconds, and then wait for at least 10 minutes before powering back ON.</li> <li>PT-N20/PT-N25BT: Disconnect the AC Adapter, remove the batteries, press and hold  for a few seconds, and then wait for at least 10 minutes before powering back ON.</li> <li>Reset the internal memory to the factory settings.</li> </ul> <p>For more information, see <i>Related Topics</i>: Reset the Label Maker.</p>
The printer and mobile device cannot connect via Bluetooth. (PT-N25BT)	<ul style="list-style-type: none"> <li>Turn the printer off, and then on again.</li> <li>If the communication error is not cleared, check your mobile device's Bluetooth screen. If the printer's name (PT-N25BT) is listed on the screen, cancel the registration by tapping the information button or setting button displayed next to the printer's name.</li> <li>Try to connect the printer again in the Brother P-touch Design&amp;Print 2 app.</li> </ul> <p>For more information, see <i>Related Topics</i>.</p>
When the green sticker holding the tape in place was peeled off, the protective film came off with it.	<p>Carefully reattach the protective film to the tape, as shown.</p> 



---

## Related Information

- [Troubleshooting](#)

### **Related Topics:**

- [Reset the Label Maker](#)
  - [Set Language](#)
  - [Check the Version Information](#)
  - [Margin Options](#)
  - [Insert Tape Cassette](#)
  - [Connect the Printer to a Mobile Device Using Bluetooth](#)
-





## Error and Maintenance Messages

>> PT-N10





>> PT-N20/PT-N25BT

### PT-N10

Message	Cause/Remedy
Battery Low!	The batteries are running low. Replace the batteries with new ones.
BatteryEmpty	Replace the batteries for uninterrupted operation.
Feed Error! Check Tape	<ul style="list-style-type: none"> <li>Remove the Tape Cassette from the Label Maker and reinsert it.</li> <li>Replace the Tape Cassette.</li> </ul>
File Missing	There is no data stored in the <code>File</code> option in the menu. Store the label data in the <code>File</code> option and then open the file.
Full!	The maximum number of characters (80 characters) has been entered.
Invalid!	Invalid value is selected for the <code>Label Length</code> option. Labels can be between 1.2" (30 mm) and 12.0" (300 mm) in length.
Line Limit!	The maximum number of printable lines has been reached.
No Text!	<ul style="list-style-type: none"> <li>There is no text file stored in the memory.</li> <li> is pressed when no text is entered.</li> <li> is pressed when no text is entered.</li> </ul>
SystemErrorX	Contact Brother Customer Service or your local Brother dealer.
Text Limit!	The number of characters entered exceeds the label length. Reduce the text or select <code>Auto</code> as the label length.
UnitCooling	If the Print Head becomes too hot, your Label Maker will stop printing and cool down. Do not touch the Label Maker when it is cooling down.

### PT-N20/PT-N25BT

Message	Cause/Remedy
2 Line Limit	The maximum number of printable lines has been reached.
Battery Empty	Replace the batteries for uninterrupted operation.
Battery Low	The batteries are running low. Replace the batteries with new ones.
Feed Error! Check Tape	<ul style="list-style-type: none"> <li>Remove the Tape Cassette from the Label Maker and reinsert it.</li> <li>Replace the Tape Cassette.</li> </ul>
File Missing	There is no data stored in the <code>File</code> option in the menu. Store the label data in the <code>File</code> option and then open the file.
Invalid	<ul style="list-style-type: none"> <li>There is no digit above the cursor when you selected the <code>Numbering</code> option.</li> <li>Invalid character is selected for the <code>Numbering</code> option.</li> <li>Invalid value is selected for the <code>Label Length</code> option. Labels can be between 1.2" (30 mm) and 12.0" (300 mm) in length.</li> </ul>
No Cassette	You tried to print, feed, or preview a label when there is no Tape Cassette installed.
No Text	<ul style="list-style-type: none"> <li>There is no text file stored in the memory.</li> </ul>

Message	Cause/Remedy
	<ul style="list-style-type: none"> <li>•  is pressed when no text is entered.</li> <li>•  and  is pressed when no text is entered.</li> <li>•  is pressed when no text is entered.</li> </ul>
SystemErrorX	Contact Brother Customer Service or your local Brother dealer.
Text Full	The maximum number of characters (80 characters) has been entered.
Text Limit Change Length	The number of characters entered exceeds the label length. Reduce the text or select <code>Auto</code> as the label length.
Transfer error (PT-N25BT)	Transfer of data failed. Try printing again.
Unit Cooling	If the Print Head becomes too hot, your Label Maker will stop printing and cool down. Do not touch the Label Maker when it is cooling down.
Wrong Adapter	An incompatible AC Adapter is connected. Use a supported AC Adapter.
Wrong Tape Use Btag tape	Installed tape is incompatible with your Label Maker. Use a Tape Cassette with the Btag mark.





## Related Information

- [Troubleshooting](#)

## Check the Version Information

**Related Models:** PT-N25BT

If you need to contact Brother with a question or regarding your warranty, you can confirm the firmware version number and other information on your Label Maker's LCD.

1. Press .
2. Press ◀ or ▶ to display the [Version Info] option, and then press .
3. Press ◀ or ▶ to display the information you want to confirm.
4. Press  to return to the Home Screen.

### Related Information

- [Troubleshooting](#)

## Reset the Label Maker











Reset the internal memory of your Label Maker to clear all saved label files or if the Label Maker is not operating correctly.

- [Reset the Printer to the Factory Settings](#)

## Reset the Printer to the Factory Settings

### NOTE

All text, format settings, option settings, and saved label files are deleted when you reset the Label Maker. Language and measurement unit settings are also deleted.

1. Turn off the Label Maker.
2. Press and hold  and  / .
3. While holding  and  / , press  and release. Release  and  / .

### NOTE

Make sure you release  before releasing the other keys.

### Related Information

- [Reset the Label Maker](#)

## Appendix

- [Specifications](#)
- [Brother Help and Customer Support](#)

## Specifications

- >> Size
- >> Environment
- >> Power Supply
- >> Media
- >> Memory
- >> Compatible Operating Systems (PT-N25BT)

### Size

<b>Weight</b>	Approximately 0.99 lb. (Approximately 450 g) (PT-N10) Approximately 1.03 lb. (Approximately 470 g) (PT-N20/PT-N25BT)
<b>Dimensions</b>	Approximately 4.6" (W) x 7.5" (D) x 2.7" (H) (Approximately 118 mm (W) x 191 mm (D) x 71 mm (H)) (PT-N10) Approximately 5.9" (W) x 5.9" (D) x 2.8" (H) (Approximately 152 mm (W) x 150 mm (D) x 72 mm (H)) (PT-N20/PT-N25BT)

### Environment

<b>Operating Temperature</b>	Between 50°F and 95°F (Between 10°C and 35°C)
<b>Operating Humidity</b>	Between 20% and 80% Maximum wet bulb temperature: 80.6°F (27°C)

### Power Supply

<b>Battery</b>	Six AAA alkaline batteries (LR03)
<b>AC Adapter (Optional)</b> (PT-N20/PT-N25BT)	<ul style="list-style-type: none"> <li>• AD-24ESA-01</li> <li>• AD-24ESAW-01</li> </ul>

### Media

<b>Tape Width</b>	Standard Btag Tape Cassette: 0.47" (12 mm)
<b>No. of Lines</b>	1 - 2 lines

For a list of compatible supplies, visit the Brother support website at [support.brother.com](http://support.brother.com)

### Memory

<b>Text Buffer</b>	Maximum 80 characters
<b>File Storage</b>	Maximum 10 files

### Compatible Operating Systems (PT-N25BT)

For the latest list of compatible software, visit [support.brother.com/os](http://support.brother.com/os).

### ✓ Related Information

- [Appendix](#)

## Brother Help and Customer Support

### IMPORTANT

For technical help, you must call the country where you bought the machine. Calls must be made **from within** that country.

>> [FAQs \(Frequently Asked Questions\)](#)

>> [For Customer Service](#)

>> [Ordering Accessories and Supplies](#)

### FAQs (Frequently Asked Questions)

For more information on your Brother machine, visit the Brother support website at [support.brother.com](http://support.brother.com). For additional help and tips, go to your model's **FAQs & Troubleshooting** page.

### For Customer Service

#### In USA:

[www.brother-usa.com/support](http://www.brother-usa.com/support) (Self-Service/Email/Chat)

1-877-BROTHER (1-877-276-8437)

#### In Canada:

[www.brother.ca/support](http://www.brother.ca/support)

(Self-Service Videos, Email, Chat, Facebook and X Help)

### Service Center Locator (USA only)

For the location of a Brother authorized service center, call 1-877-BROTHER (1-877-276-8437) or visit [www.brother-usa.com/support](http://www.brother-usa.com/support).

### Service Center Locations (Canada only)

For the location of a Brother authorized service center, visit [www.brother.ca/support](http://www.brother.ca/support).

### Ordering Accessories and Supplies

We recommend Genuine Brother supplies, which are available at most Brother retailers. If you cannot find the supplies you need and have a Visa, MasterCard, Discover, American Express credit card, or PayPal account, you can order directly from Brother. Visit us online for a complete selection of the Brother accessories and supplies that are available for purchase.

### NOTE

In Canada, only Visa and MasterCard are accepted.

#### In USA:

1-877-BROTHER (1-877-276-8437)

[www.brother-usa.com/support](http://www.brother-usa.com/support)

#### In Canada:

[www.brother.ca](http://www.brother.ca)





## Related Information

- [Appendix](#)
-

brother



USA/CAN  
Version 0